



GENERAL DESCRIPTION

REDA Fire & Hazard Control Series 600 wet barrel fire hydrant assemblies are custom designed and fabricated to the specific needs of each customer. The units meet or exceed applicable sections of NFPA and other industrial standards. In addition, the fire hydrant assemblies meet both firefighting and extreme environmental requirements of the Middle East region.

The purpose of the wet barrel fire hydrants is to provide pressurized fire water supply connections from on-site fire pump and water main distribution systems. The fire hydrant assemblies are available with various size inlet connections, multiple discharge hose line connections, a pumper connection, plus a top mounted monitor and nozzle. Due to extreme outdoor applications and atmospheric conditions, the fire hydrants are supplied with brass valves and painted steel or special coatings.

FIRE HYDRANT FEATURES

Piping: ASTM A106 Gr.B, AST A53 Gr.B, or API 5 Gr.B

Welding: ASME IX Welding Code and Approved WPS and PQR

Fasteners: Hot-dipped Galvanized

Inlets: Flanged 100 or 150 mm (4" or 6") Sizes

Testing: Hydrostatically Tested to 17 Bar (250 PSI) or as Specified

Corrosion Protection: Hot-dip Galvanized, Epoxy, or FBE Coatings

Inlets: 100 mm, 150 mm, 200 mm, 250 mm, 300 mm (4", 6", 8", 10", and 12" Sizes), Flanged or Threaded

FIRE HYDRANT AND MONITOR ASSEMBLY

FIRE HYDRANT AND MONITOR ASSEMBLY

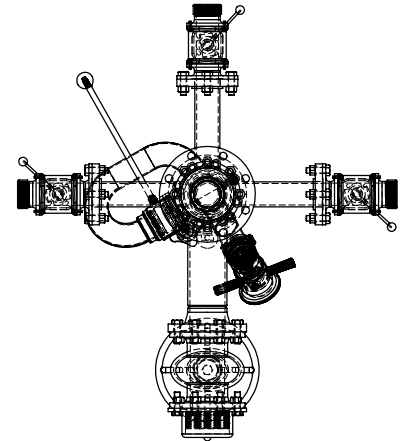
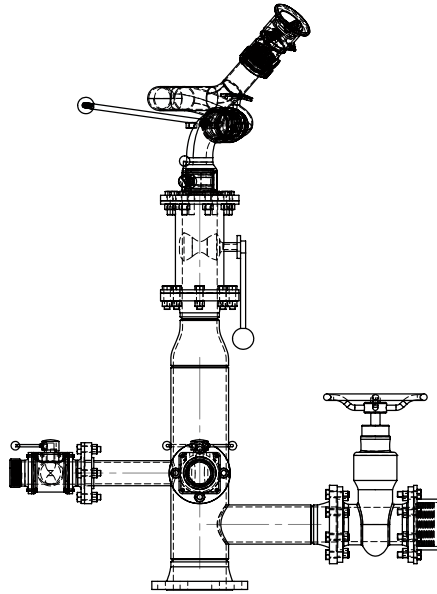
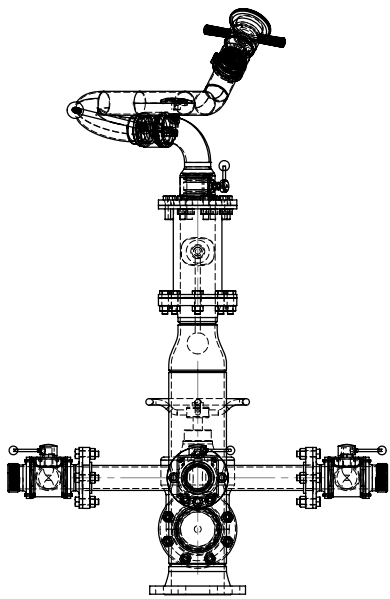

STANDARD FEATURES

INLET PIPE - BOTTOM

Sizes: Flanged 100 mm (4") or 150 mm (6")

HOSE CONNECTIONS

Type: BS, NH, Storz, Other: _____

Outlet Connections: 65 mm (2.5") and 75 mm (3")

Valve Types: Gate or Ball

Valve Operation: Handwheel or Gear Type

PUMPER CONNECTION

Type: BS, NH, Storz, Other: _____

Outlet: 100 mm (4") or 125 mm (5") or 150 mm (6")

Valve Types: Gate or Ball

Valve Operation: Handwheel or Gear Type

MONITOR

LPM Flow: 1800, 2800, 3700, 4700

(GPM Flow: 500, 750, 1000, 1250)

Inlet: 65 mm (2.5") or 75 mm (3") or 100 mm (4")

Control Type: Manual or Remote Control

Valve Type: Gate, Butterfly or Ball

Monitor Operation: Handwheel, Gear or Tiller Bar

NOZZLE

Type: Water Only or Foam Self-Educting with Pick-Up Tube

Flow: Fixed GPM/LPM or Adjustable Flow

PAINTING

Internal: Epoxy Paint, FBE Coating, or HD Galvanized

External: Epoxy Paint, FBE Coating, or HD Galvanized

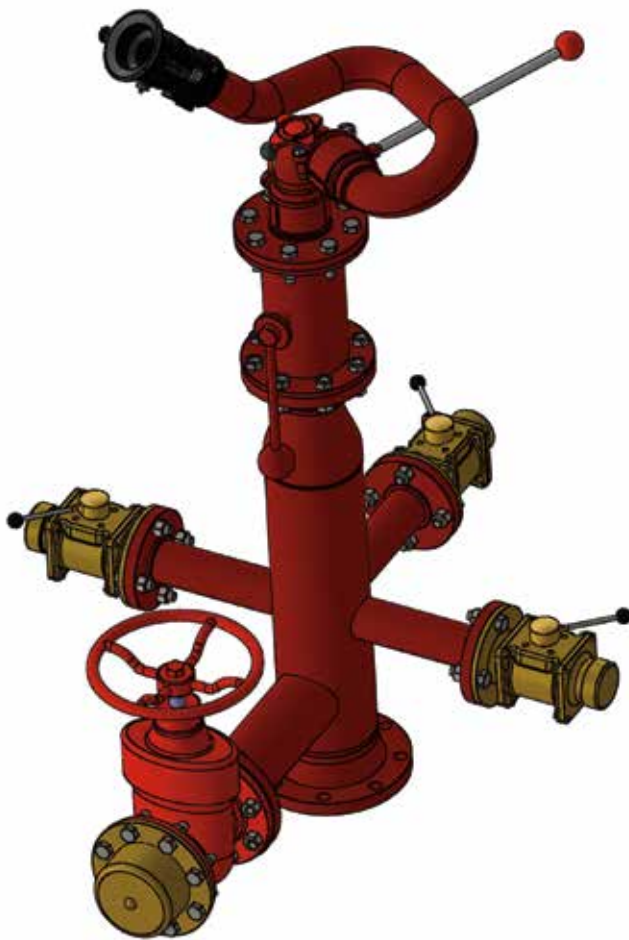

**Custom Design Services
Available for Specific Purchaser
Requirements**